



HOSHIZAKI

Undercounter Refrigerator/Freezer

MADE IN JAPAN



RT-120SNG

DESCRIPTION

- Digital temperature display and automatic defrost system;
- Auto-close within 45°C and automatically door-closing design with 700,000 tests;
- Designed to operate in 43°C ambient conditions;
- Removable door gaskets and dished stainless interior with round edged for easy cleaning;
- Internal structure with R-angle design for easy cleaning;
- Extremely large storage capacity and suitable for GN standard tray;
- Evaporator surface with anti-corrosion treatment;
- Refrigerator leg can be replaced by castor for easy movement.

PRODUCT DRAWINGS

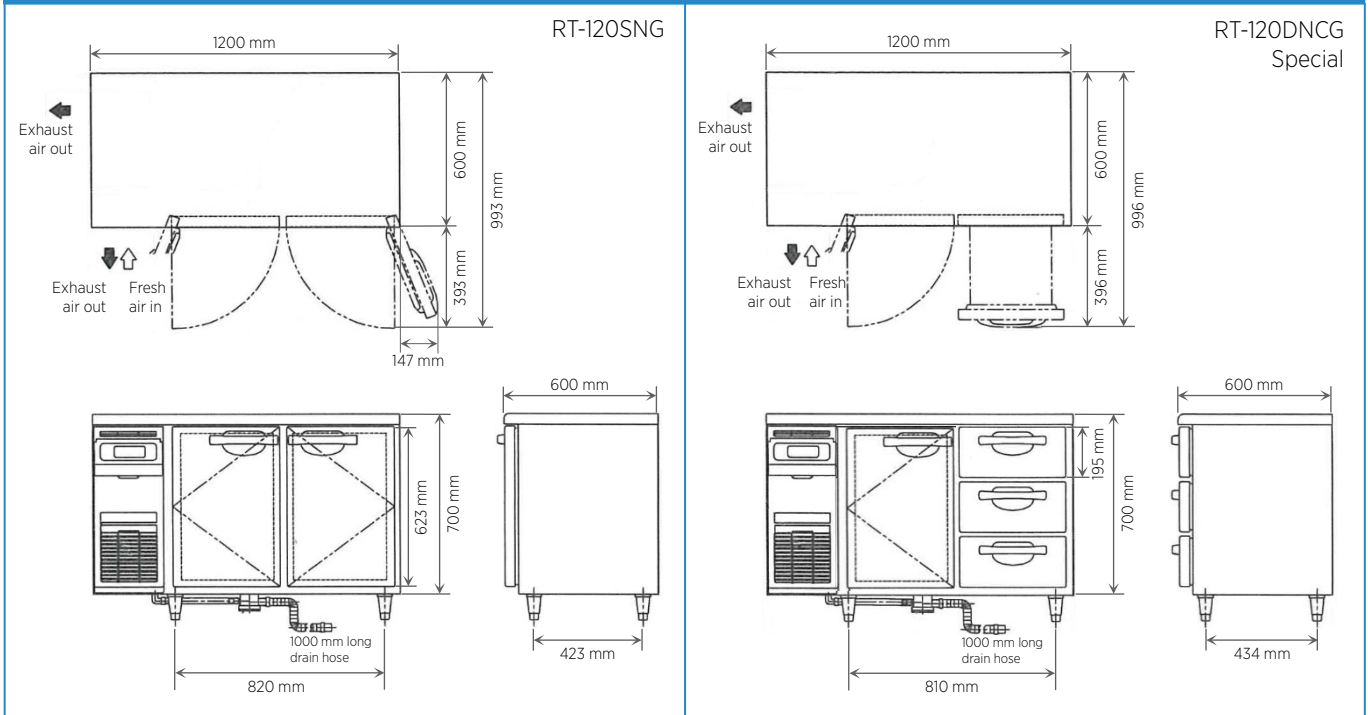

PRODUCT SPECIFICATIONS

Model	RT-120SNG	RT-120DNCG-Spec
Capacity	243 ltr	180 ltr
Designed temperature	-6°C - +12°C	-6°C - +12°C
No. of door	2 doors	1 door, 3 drawers
Refrigerant	R134a	R134a
Drain size	Ø 20 mm	Ø 20 mm
Elect. loading	220V / 50Hz / 1ph, 350W	220V / 50Hz / 310W
Dimension (W x D x H)	1200 x 600 x 800 mm	1200 x 600 x 800 mm
Net weight	68 kg	84 kg